



FITTING INSTRUCTIONS for...

- BMW R 1300 GS ('2024 on)

www.barkbusters.net

Preparation

Remove original handguards if fitted. Retain the OEM bar end weight.



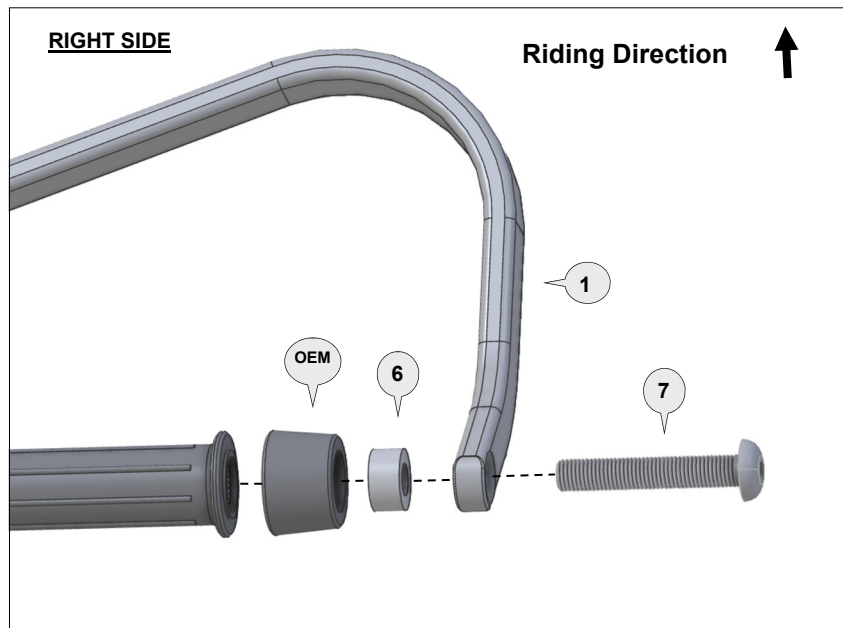
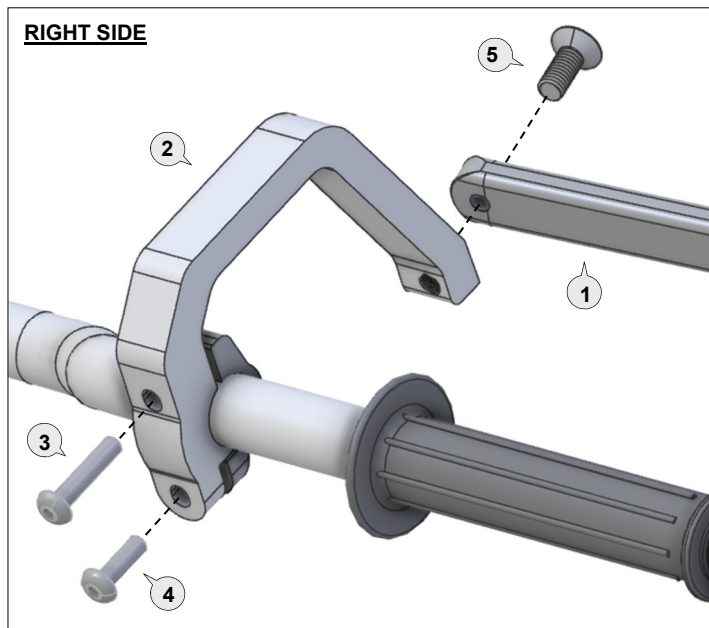



Only for models without indicators in the OEM handguards or with Enduro Package Pro Fitted.

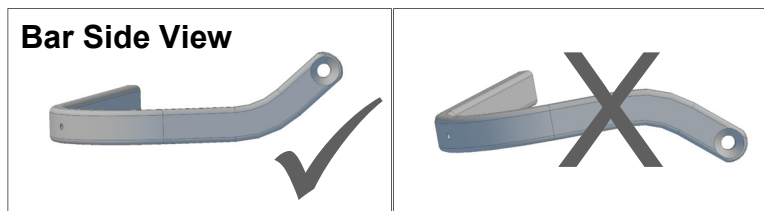

Installation:

- Loosely assemble the clamp (2) to the handlebar as per diagram.
- Attach the handguard backbone (1) with applicable parts to the handlebar end making sure to retain the OEM bar end weight.
- Align the clamp (2) with the backbone end hole and insert screw (5).
- Position backbone so it is horizontal when viewed from the side.
- Tighten all bolts to the specified torque (over page) in the following order: (7), (5), tight (3) and (4) simultaneously to keep an even gap with the clamp saddle.

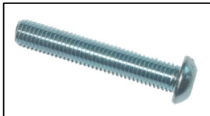

<p>1 Aluminium Bar</p>  <p>PN: BAR-BV065 Pcs. 1 Left & 1 Right</p>	<p>2 Clamp Frame & Saddle</p>  <p>PN: CFS-ADV-24 Pcs. 1 set</p>	<p>3 Button Head Bolt 30mm</p>  <p>PN: M6X30BHCSZP Pcs. 2</p>	<p>4 Button Head Bolt 20mm</p>  <p>PN: M6X20BHCSZP Pcs. 2</p>	<p>5 Socket Head Bolt 25mm</p>  <p>PN: M8X25FHCSZP Pcs. 2</p>	<p>6 Spacer 10mm</p>  <p>PN: SP07-20-10 Pcs. 2</p>	<p>7 Button Head Bolt 60mm</p>  <p>PN: M10X60BHCSZP Pcs. 2</p>
--	---	---	--	---	--	--

Recommended Torque Settings	
M6	10 Nm (7.4 lbf ft)
M8	20 Nm (14.8 lbf ft)
M10	32 Nm (15.5 lbf ft)

CAUTION:

Installation of the handguard is safety-relevant work and can be complicated. We recommend the installation be performed by a motorcycle service technician. Rideworx accepts no liability for damages caused by improper mounting. All screws, bolts and nuts, including all replacement hardware provided by Rideworx, should be tightened to the torque specified in the table. After the first 50km of riding check all screws, bolts and nuts are tightened to the correct torque. We recommend a medium strength liquid thread lock product on all fasteners.

WARNING:

It is important there is a working clearance (approx 3mm) between the throttle grip end and the handguard to ensure a free closing throttle. Check operation of all handlebar controls, specifically the throttle, front brake, kill switch and clutch to ensure they are operating correctly and are in accordance with the OEM specifications. Do not ride the motorcycle if any controls are not operating correctly. Check periodically that all bolts are tight. Please note that all Rideworx test fitment are done on stock motorcycles with factory standard handle bar, windscreen, etc. in there original positions.

Disclaimer:

A failure to follow these fitting instructions could cause serious injury, death or property damage. These handguards are intended solely for use with motorcycles/ATV/snowmobiles/scooters that have not been modified. They are not designed to prevent injury or death while riding or in an accident or crash. The user must ensure that all controls are free of the handguards every time that they ride. By installing and/or using this product you acknowledge that you accept these terms and have followed the fitting instructions.

Personalise Your Protection
Guard options sold separately

JET JET-003
VPS VPS-003
Storm STM-003
CARBON BCF-003



Email: info@barkbusters.net

@BARKBUSTERSHANDGUARDS



Barkbusters

FITTING INSTRUCTIONS for Carbon Fibre Handguard

Option for fitting with **Single Point Handlebar Mount** (sold separately)

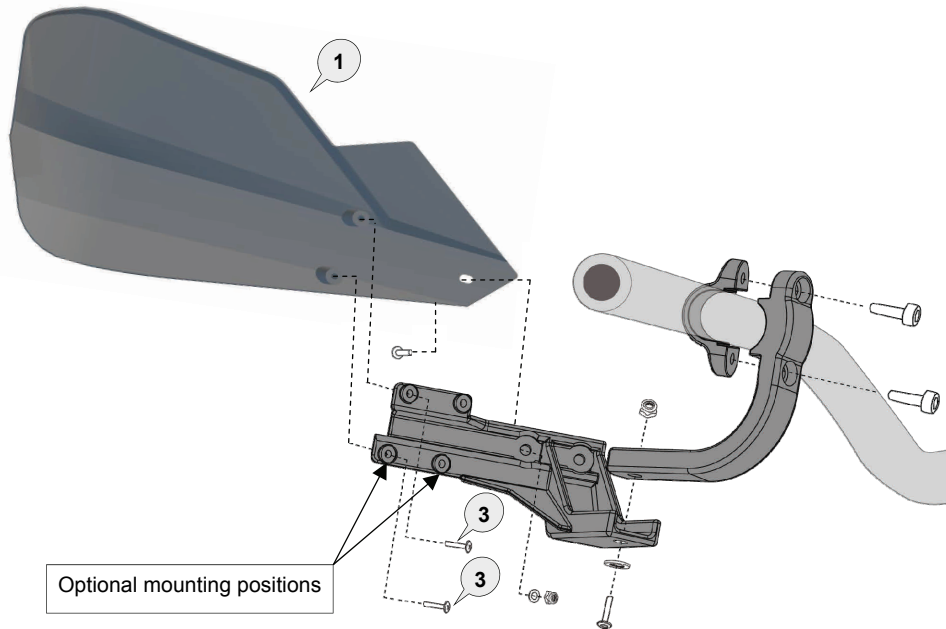

Option for fitting with Barkbusters **Aluminium Backbone** (sold separately)

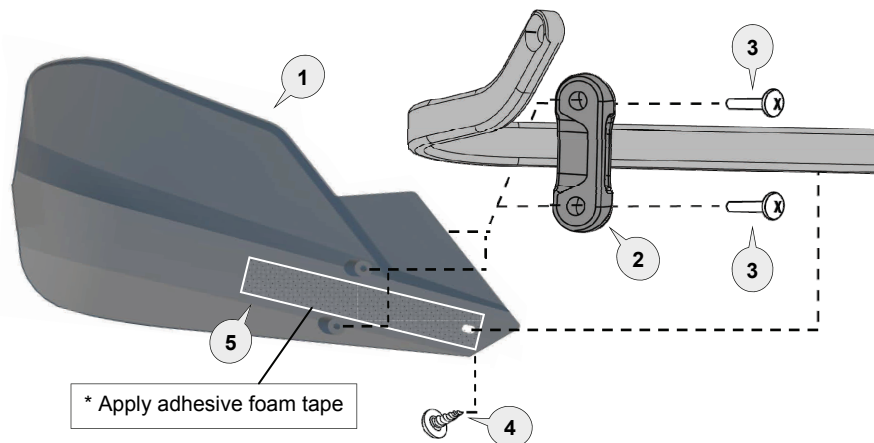

1 Carbon Fibre Guard



PN: BCF

Pcs. 2 (L/R)

2 Saddle



PN: Storm-Saddle

Pcs. 2

3 Pan Head Screw



PN: M4x10PHZP

Pcs. 4

4 Screw



PN: STSZ811MX11

Pcs. 2

5 Foam Tape



PN: FT1

Pcs. 2

CAUTION:

Installation of the handguard is safety-relevant work and can be complicated. We recommend the installation be performed by a motorcycle service technician. Rideworx accepts no liability for damages caused by improper mounting. All screws, bolts and nuts, including all replacement hardware provided by Rideworx, should be tightened to the torque specified in the below table. After the first 50km of riding check all screws, bolts and nuts are tight. We recommend a medium strength liquid thread lock product on screw (3).

WARNING:

Check operation of all handlebar controls, specifically the throttle, front brake, kill switch and clutch to ensure they are operating correctly and are in accordance with the OEM specifications. Do not ride the motorcycle if any controls are not operating correctly. Check periodically that all bolts are tight.

Disclaimer:

A failure to follow these fitting instructions could cause serious injury, death or property damage. These handguards are intended solely for use with motorcycles/ATV/snowmobiles/scooters that have not been modified. They are not designed to prevent injury or death while riding or in an accident or crash. The user must ensure that all controls are free of the handguards every time that they ride. By installing and/or using this product you acknowledge that you accept these terms and have followed the fitting instructions.



Phone: +61 (0)2 4271 8244
Email: info@barkbusters.net
Web: www.barkbusters.net