

Numero di articolo: **MSS.04.521.10002/B**Revisione: **00** · Data: **12 - 2023****paracoppa** ~ 1 h.FACILE     DIFFICILE

**ITALIANO** -Grazie per aver scelto questo prodotto premium di SW-MOTECH. Visita il nostro negozio online per ulteriori informazioni (ad es. per la compatibilità con i vari modelli). I documenti richiesti (ad es. certificato di omologazione nazionale) possono essere scaricati qui.

**Si prega di leggere attentamente le avvertenze di sicurezza e le istruzioni per il montaggio prima di montare e utilizzare il prodotto, al fine di evitare eventuali lesioni e danni. Conserva queste istruzioni per il montaggio come riferimento futuro.**

**Questo prodotto è stato sviluppato per veicoli in condizioni di fabbrica. La compatibilità con gli accessori originali o di altri produttori non può essere garantita.**

**Queste istruzioni per il montaggio sono state redatte in base alle nostre conoscenze attuali. Non sussistono pretese di correttezza giuridiche. Salvo errori ed omissioni. Ci riserviamo il diritto di apportare modifiche tecniche e di design. Copyright SW-MOTECH.**

**SIMBOLO DI SICUREZZA**

 Questo simbolo di avvertenza è usato nelle presenti istruzioni di montaggio per segnalare pericoli mortali, rischio di lesioni o altri pericoli. Le parole "PERICOLO", "AVVERTENZA" O "ATTENZIONE" sono utilizzate con questo simbolo di avvertenza per trasmettere importanti istruzioni di sicurezza e informazioni relative al montaggio e all'uso di questo prodotto. Queste parole, utilizzate insieme al simbolo di avvertenza, significano:

 **PERICOLO:** indica una situazione di pericolo che, se non evitata, può causare morte o lesioni gravi!

 **AVVERTENZA:** indica una situazione di pericolo che, se non evitata, può causare morte o lesioni gravi!

 **ATTENZIONE:** indica una situazione di pericolo che, se non evitata, può provocare lesioni lievi o di entità moderata!

 **AVVISO:** indica informazioni importanti che non riguardano il rischio di morte o di lesioni (riguardano unicamente il rischio di danni materiali)!

**INFORMAZIONI GENERALI**

 **AVVERTENZA:** il montaggio e/o la manutenzione di questo prodotto richiedono competenze tecniche avanzate, strumenti adeguati e una buona conoscenza dell'uso della strumentazione e delle indicazioni relative alle coppie di serraggio. Per ragioni di sicurezza, SW-MOTECH raccomanda di far eseguire il montaggio e/o la manutenzione presso un'officina per motociclette qualificata e certificata.

 **AVVERTENZA:** se si decide di installare questo prodotto in autonomia, leggere attentamente le istruzioni per il montaggio prima del montaggio e dell'uso e seguire tutte le avvertenze per evitare lesioni gravi o mortali. Durante il montaggio e l'uso, seguire anche tutte le istruzioni pertinenti contenute nel manuale del veicolo. **SE NON SI COMPRENDONO TALI ISTRUZIONI, ANCHE SOLO IN PARTE, O SE SONO NECESSARI CHIARIMENTI, NON CERCARE DI MONTARE IL PRODOTTO IN AUTONOMIA SENZA CHIEDERE IL SUPPORTO DI SW-MOTECH!**

**PREPARAZIONE:** leggere attentamente le istruzioni per il montaggio e assicurarsi che siano disponibili tutti i componenti contenuti nella lista.

 **ATTENZIONE:** assicurarsi che il veicolo sia perfettamente fermo. Spegner il motore e togliere la chiave. Se necessario, lasciar raffreddare il motore/lo scarico. Scollegare la batteria quando si interviene sull'impianto elettrico. Usare esclusivamente strumenti idonei e indossare sempre occhiali e guanti protettivi durante le operazioni di montaggio e manutenzione. Chiedere aiuto a una seconda persona durante le fasi di montaggio e manutenzione.

**MONTAGGIO:** tutti i componenti e i collegamenti rimossi dal veicolo devono essere reinstallati secondo le specifiche del produttore del veicolo o sostituiti con componenti e attrezzatura forniti da SW-MOTECH.

 **AVVERTENZA:** fissare tutte le filettature con frenafili liquido a media resistenza, se non diversamente specificato.

 **PERICOLO:** le coppie di serraggio non definite da SW-MOTECH devono essere richieste al costruttore del veicolo o a un'officina certificata.

**CONTROLLO DI FUNZIONALITÀ:** dopo il montaggio accertarsi che non vi siano parti mobili bloccate e che il funzionamento del veicolo non sia compromesso. I cavi e i tubi flessibili non devono sfregare e/o essere schiacciati.

 **AVVERTENZA:** eseguire un controllo completo delle funzioni prima di mettersi alla guida. Controllare la coppia di serraggio di tutti i collegamenti e la tenuta del prodotto dopo i primi 50 km e in seguito regolarmente. Gli accessori montati possono modificare la maneggevolezza e la stabilità del veicolo.



SW-MOTECH GmbH & Co. KG  
Ernteweg 7-10  
35282 Rauschenberg  
Germania



[info@sw-motech.com](mailto:info@sw-motech.com)  
[www.sw-motech.com](http://www.sw-motech.com)



Consultare i simboli e il loro significato nella sezione MONTAGGIO. Se nella sezione montaggio compare la sigla OEM, è necessario rispettare e applicare le specifiche del produttore del veicolo.



Per qualsiasi domanda, non esitare a contattare il nostro servizio clienti o i nostri distributori. Il nostro numero di telefono e l'elenco dei nostri distributori sono disponibili nel nostro negozio online:

**[www.sw-motech.com](http://www.sw-motech.com)**









































**Usare un frenafiletto:** indica che la filettatura deve essere rivestita con un frenafiletto liquido. H (ALTA): alta resistenza; M (MEDIA): media resistenza; L (BASSO): bassa resistenza.

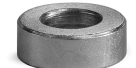

**Serraggio / rispetto delle specifiche sulla coppia di serraggio:** indica la coppia di serraggio di un componente specificata da SW-MOTECH o dal produttore del veicolo (OEM).

ELENCO DELLE PARTI - LEGGI E CONSERVA LE ISTRUZIONI DI MONTAGGIO!

<p><b>4</b></p> <p><b>1</b></p>  <p>MSS.04.521.006.11</p> <p> 1/1</p>	<p><b>2</b></p>  <p>M6 x 40; DIN 931 SC.ST.06.040.01.931.088</p> <p> 2/2</p>	<p><b>3</b></p>  <p>M6 x 25; DIN 933 SC.ST.06.025.01.933.088</p> <p> 2/2</p>	<p><b>4</b></p>  <p>ø 6,4; DIN 125 US.ST.064.02.125</p> <p> 4/6</p>	<p><b>5</b></p>  <p>Ø 14 / ø 6,4 / h 21 DB.00.140.064.021.02</p> <p> 2/2</p>	<p><b>6</b></p>  <p>Ø 14 / ø 6,4 / h 6 DB.ST.0140.0064.0060.01</p> <p> 2/2</p>
<p><b>7</b></p>  <p>MSS.04.521.004.11</p> <p> 2/2</p>					
<p><b>5</b></p> <p><b>8</b></p>  <p>MSS.04.521.007.11</p> <p> 1/1</p>	<p><b>9</b></p>  <p>M6 x 20; DIN 933 SC.ST.06.020.01.933.088</p> <p> 2/2</p>	<p><b>10</b></p>  <p>ø 6,4; DIN 125 US.ST.064.02.125</p> <p> 2/6</p>	<p><b>11</b></p>  <p>M6; DIN 6927 MU.ST.06.02.6927.08</p> <p> 2/2</p>		
<p><b>6</b></p> <p><b>12</b></p>  <p>MSS.04.521.002.11</p> <p> 1/1</p>	<p><b>13</b></p>  <p>M8 x 40; DIN 6912 SC.ST.08.040.01.6912.088</p> <p> 1/1</p>	<p><b>14</b></p>  <p>ø 8,4; DIN 125 US.ST.084.01.125</p> <p> 2/10</p>	<p><b>15</b></p>  <p>Ø 15 / ø 8,2 / h 15 DB.00.150.082.015.01</p> <p> 2/2</p>	<p><b>16</b></p>  <p>M8 x 35; DIN 6912 SC.ST.08.035.01.6912.088</p> <p> 1/1</p>	<p><b>17</b></p>  <p>M8 x 20; DIN 6912 SC.ST.08.020.01.6912.088</p> <p> 1/2</p>
<p><b>18</b></p>  <p>ø 8,4; DIN 9021 US.ST.084.01.9021.300</p> <p> 1/2</p>					
<p><b>7</b></p> <p><b>19</b></p>  <p>MSS.04.521.003.11</p> <p> 1/1</p>	<p><b>20</b></p>  <p>M8 x 45; DIN 6912 SC.ST.08.045.01.6912.088</p> <p> 1/1</p>	<p><b>21</b></p>  <p>ø 8,4; DIN 125 US.ST.084.01.125</p> <p> 2/10</p>	<p><b>22</b></p>  <p>Ø 16 / ø 8,5 / h 17 DB.ST.160.085.017.01</p> <p> 1/1</p>	<p><b>23</b></p>  <p>M8 x 25; DIN 6912 SC.ST.08.025.01.6912.088</p> <p> 1/1</p>	<p><b>24</b></p>  <p>Ø 15 / ø 8,4 / h 5 DB.00.150.084.005.01</p> <p> 1/1</p>

ELENCO DELLE PARTI - LEGGI E CONSERVA LE ISTRUZIONI DI MONTAGGIO!

**25**



M8 x 20; DIN 6912  
SC.ST.08.020.01.6912.088

 1/2

**26**



ø 8,4; DIN 9021  
US.ST.084.01.9021.300

 1/2

**27**



KB.PA.048.178.02

 1/1

**8**

**28**



MSS.04.521.900.02

 1/1

**29**



MSS.04.521.008L.02

 1/1

**30**



MSS.04.521.008R.02

 1/1

**31**



MSS.04.521.009L.02

 1/1

**32**



MSS.04.521.009R.02

 1/1

**11**

**33**



M8 x 20; DIN 933  
SC.ST.08.020.01.933.088

 6/6

**34**



ø 8,4; DIN 125  
US.ST.084.01.125

 6/10

**35**



M6 x 20; DIN 965  
SC.ST.06.020.01.965TX.088

 8/8

**36**



ø 6,4  
SE.00.064.01

 8/8

**37**



M6 x 35; DIN 931  
SC.ST.06.035.01.931.088

 4/4

**39**



Ø 20 / ø 6,4 / h 5  
DB.00.200.064.005.01

 4/4

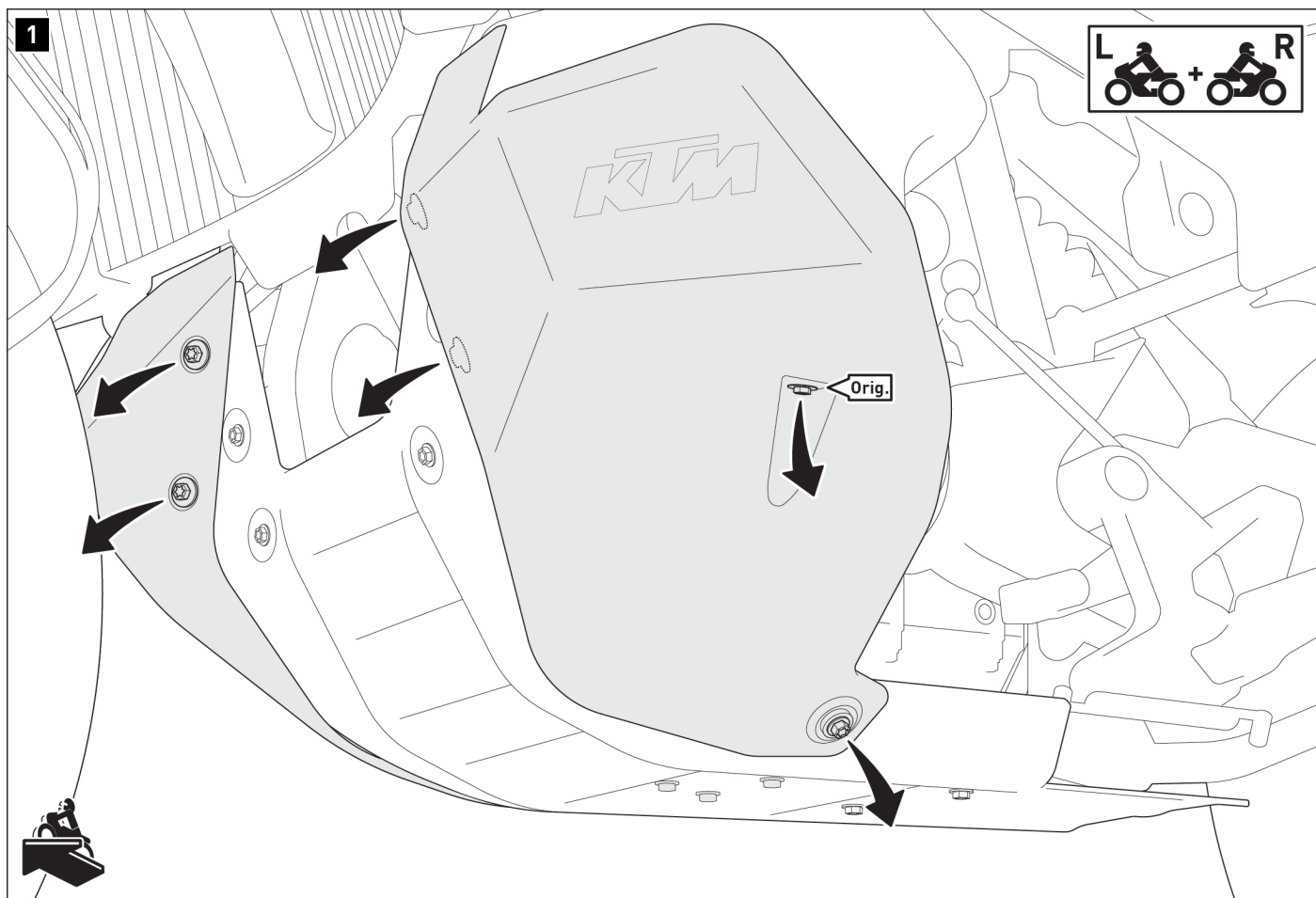

- ▲ **AVVERTENZA: indossare sempre le protezioni per gli occhi e per le mani!**
- ▲ **AVVERTENZA: Utilizzare sempre strumenti adeguati!**

Allentare le viti mostrate su entrambi i lati e rimuovere i pannelli del serbatoio dal veicolo. Le viti contrassegnate con (Orig.) saranno necessarie al passaggio [4].

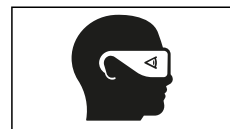

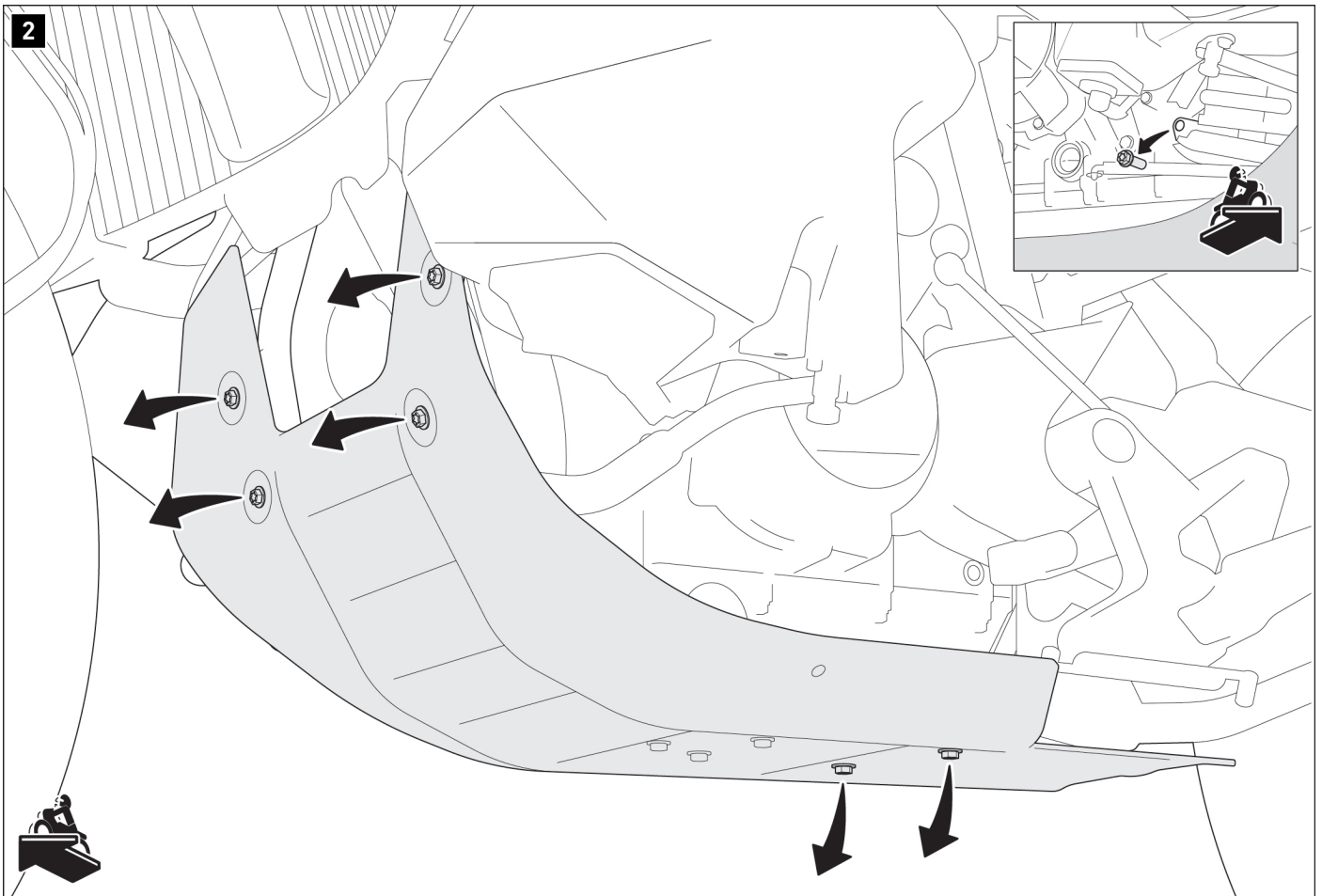

Rimuovere la vite originale mostrata in dettaglio nell'illustrazione dal lato destro del veicolo.  
Allentare le viti indicate della protezione motore originale e rimuovere quest'ultima dal veicolo.

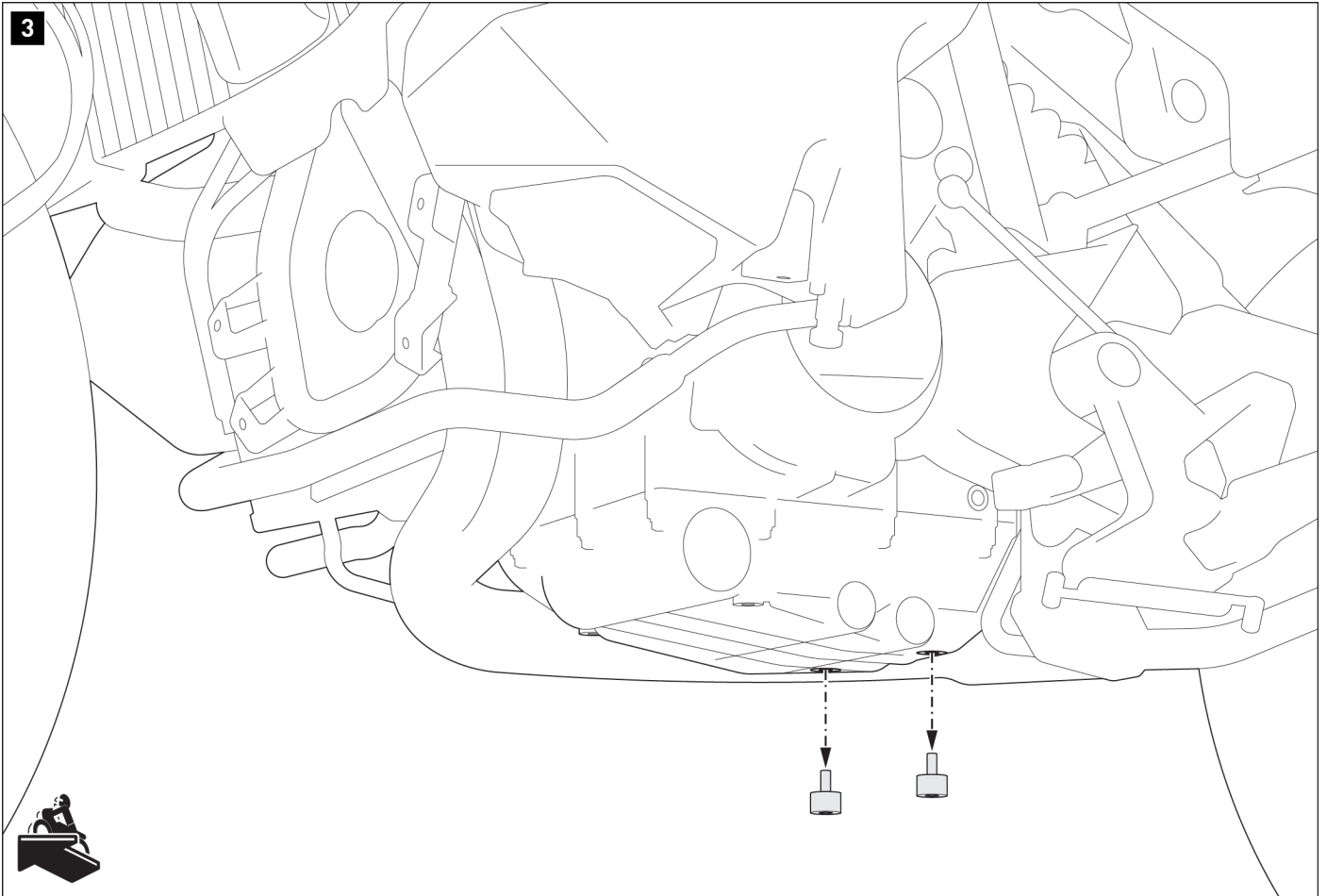

Rimuovere gli ammortizzatori in gomma originali mostrati.

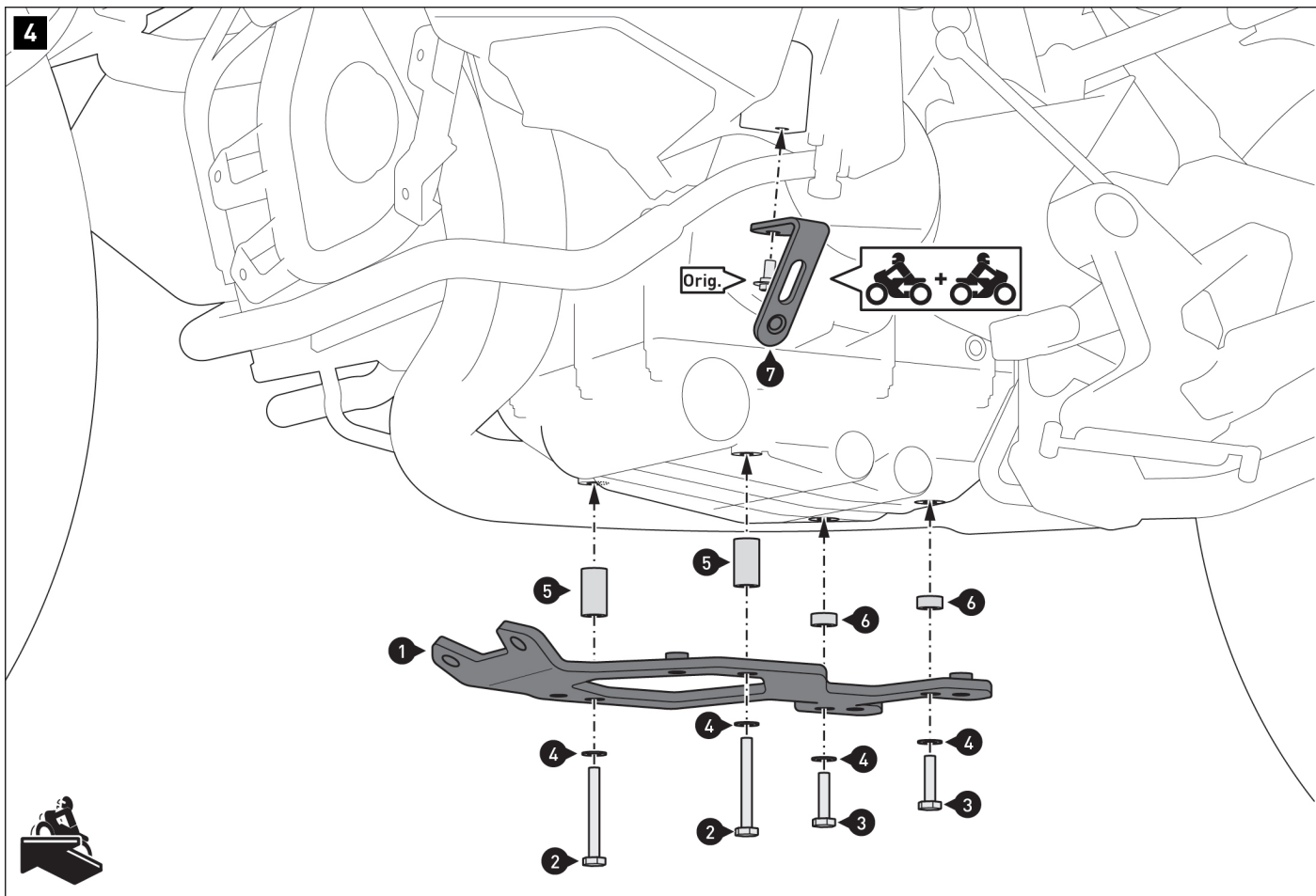

Avvitare la staffa di montaggio inferiore (1) e la staffa angolare (7) al veicolo.  
**⚠ AVVERTENZA: utilizzare un frenafili liquido per le viti (2) e (3)!**  
 Non serrare ancora le viti.

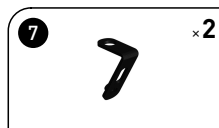
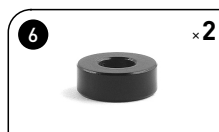
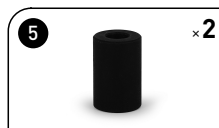
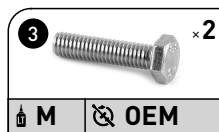
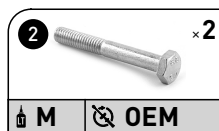
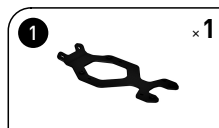



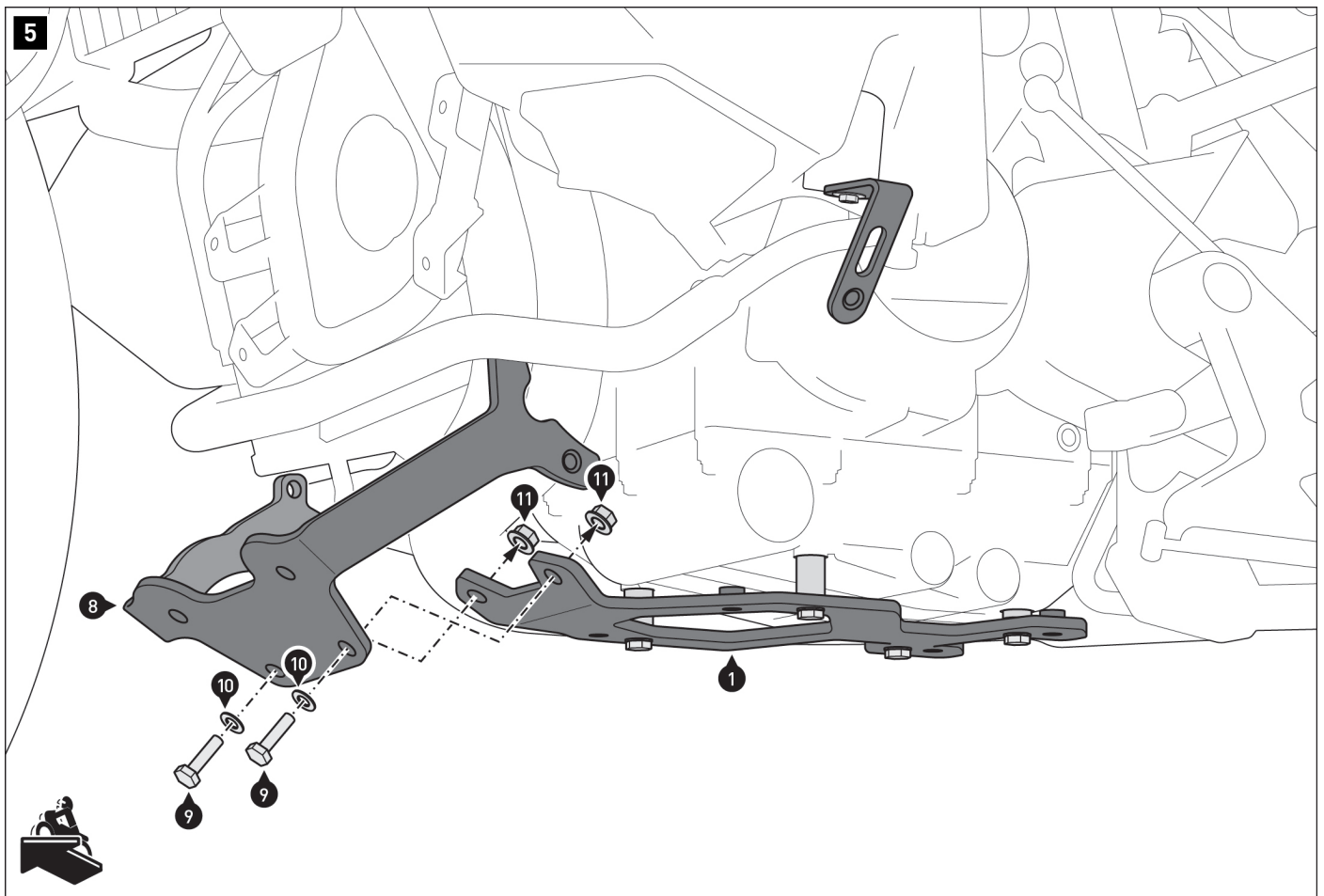

Avvitare la staffa di montaggio anteriore (8) alla staffa di montaggio (1).  
Non serrare ancora le viti.

CONSIGLIO: prima di effettuare il montaggio, fissare i dadi (11) sulla piastra di montaggio utilizzando una striscia adesiva (1).

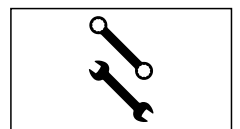
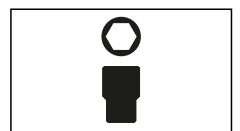
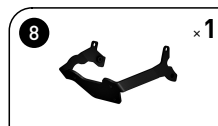

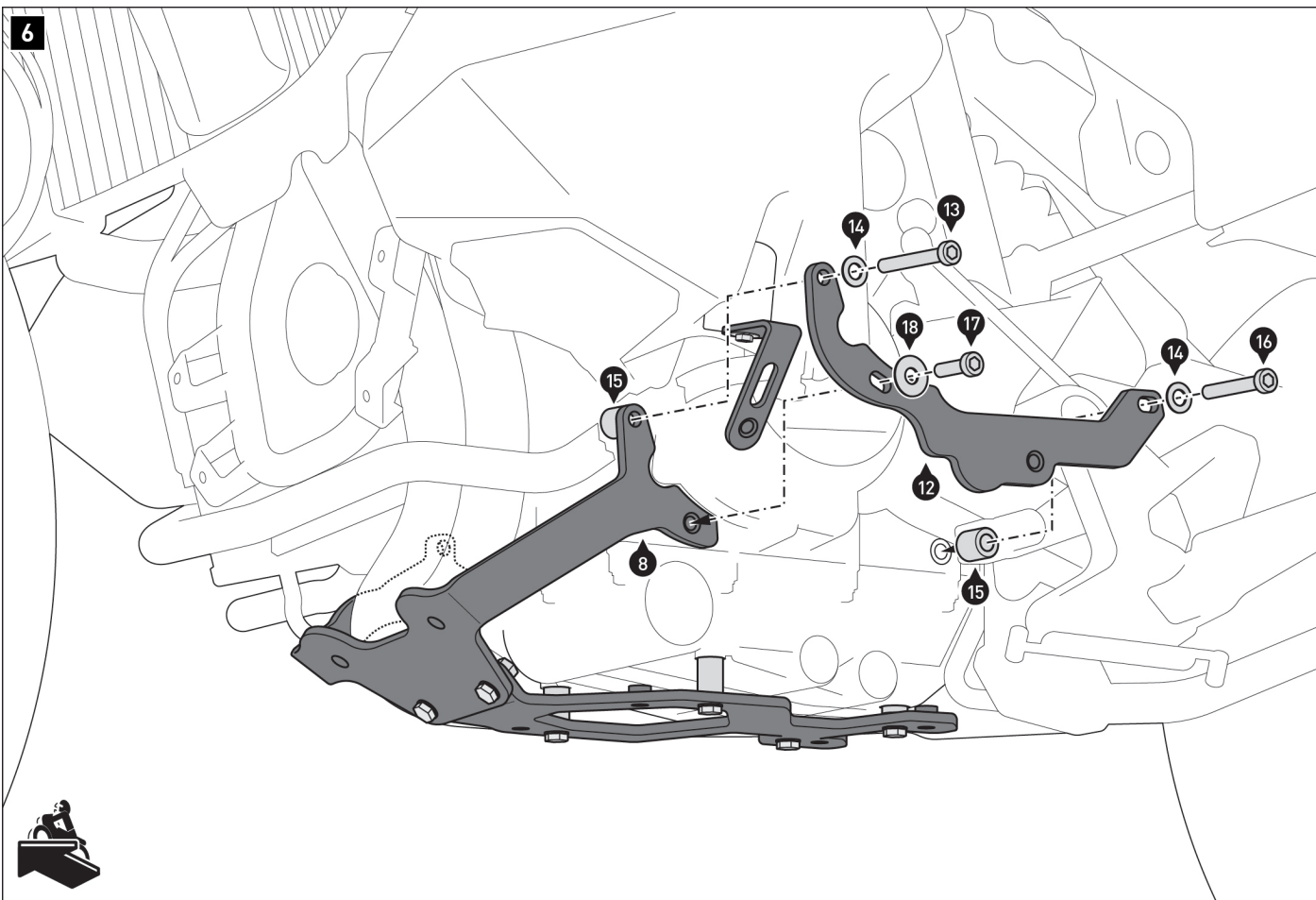

Avvitare la staffa di montaggio sinistra [12] al veicolo.  
**▲ AVVERTENZA: Usare un frenafilietti liquido!**  
 Non serrare ancora le viti.

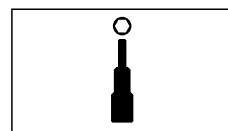
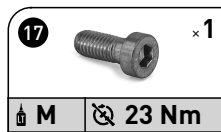
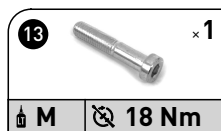
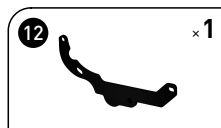

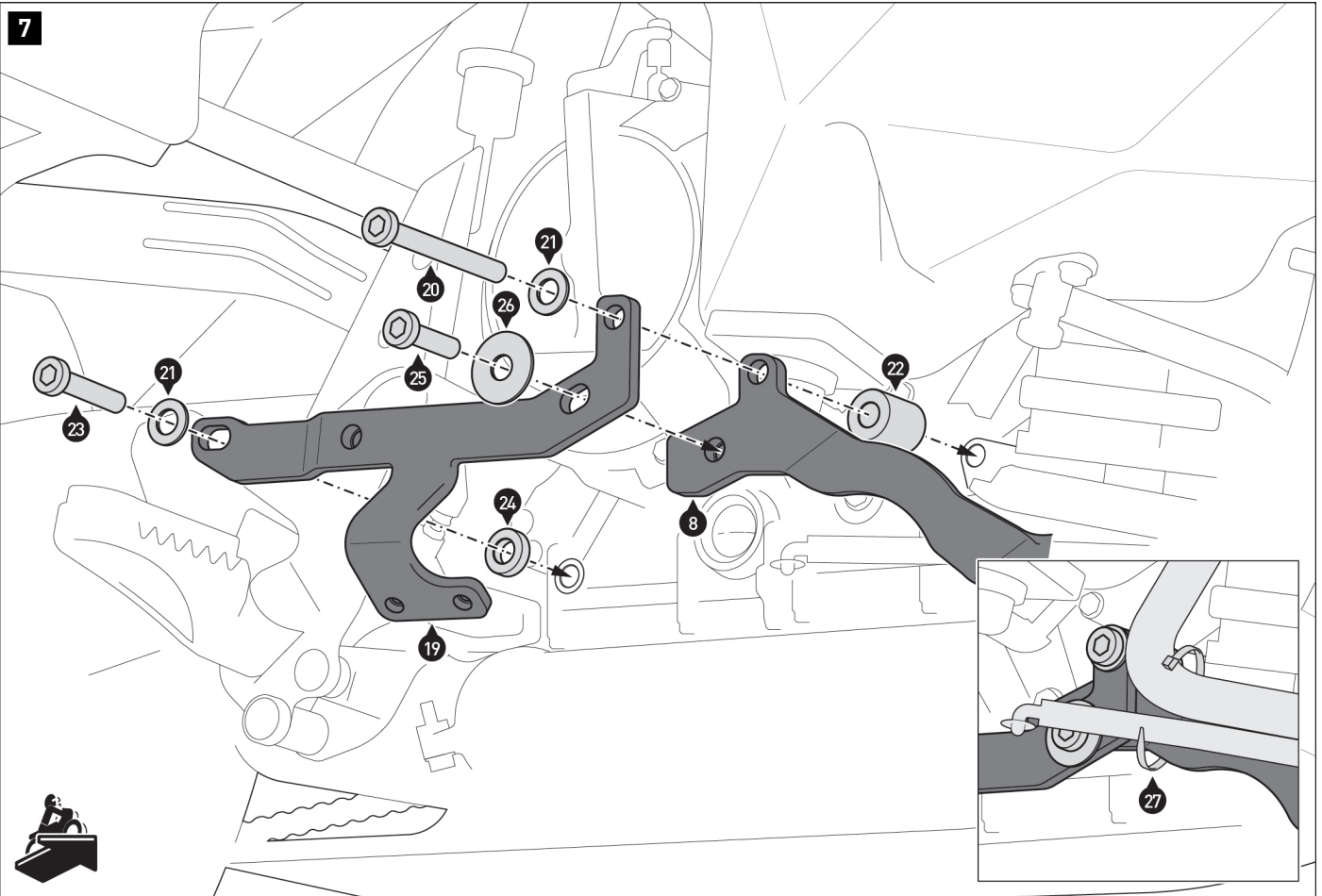

Avvitare la staffa di montaggio destra (19) al veicolo.

**▲ AVVERTENZA: Usare un frenafilietti liquido!**  
Non serrare ancora le viti.

Fissare il tubo di troppopieno alla staffa di montaggio (19) utilizzando la fascetta (27), come mostrato in dettaglio nell'illustrazione.

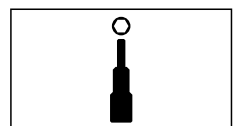
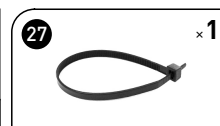

8

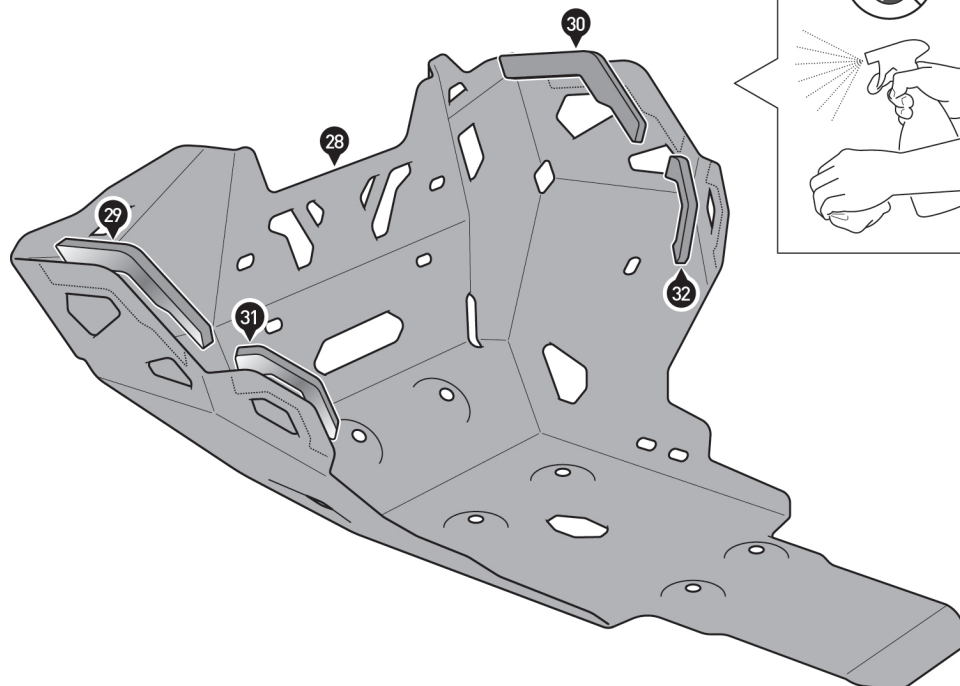

Pulire accuratamente la superficie della protezione motore (28) per rimuovere eventuali residui di grasso e sporco.  
Rimuovere le pellicole protettive dai cuscinetti in gomma (29) a (32).  
Incollare i cuscinetti in gomma (29) a (32) all'interno della protezione motore (28).

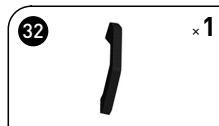
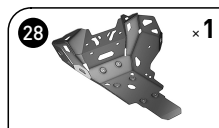

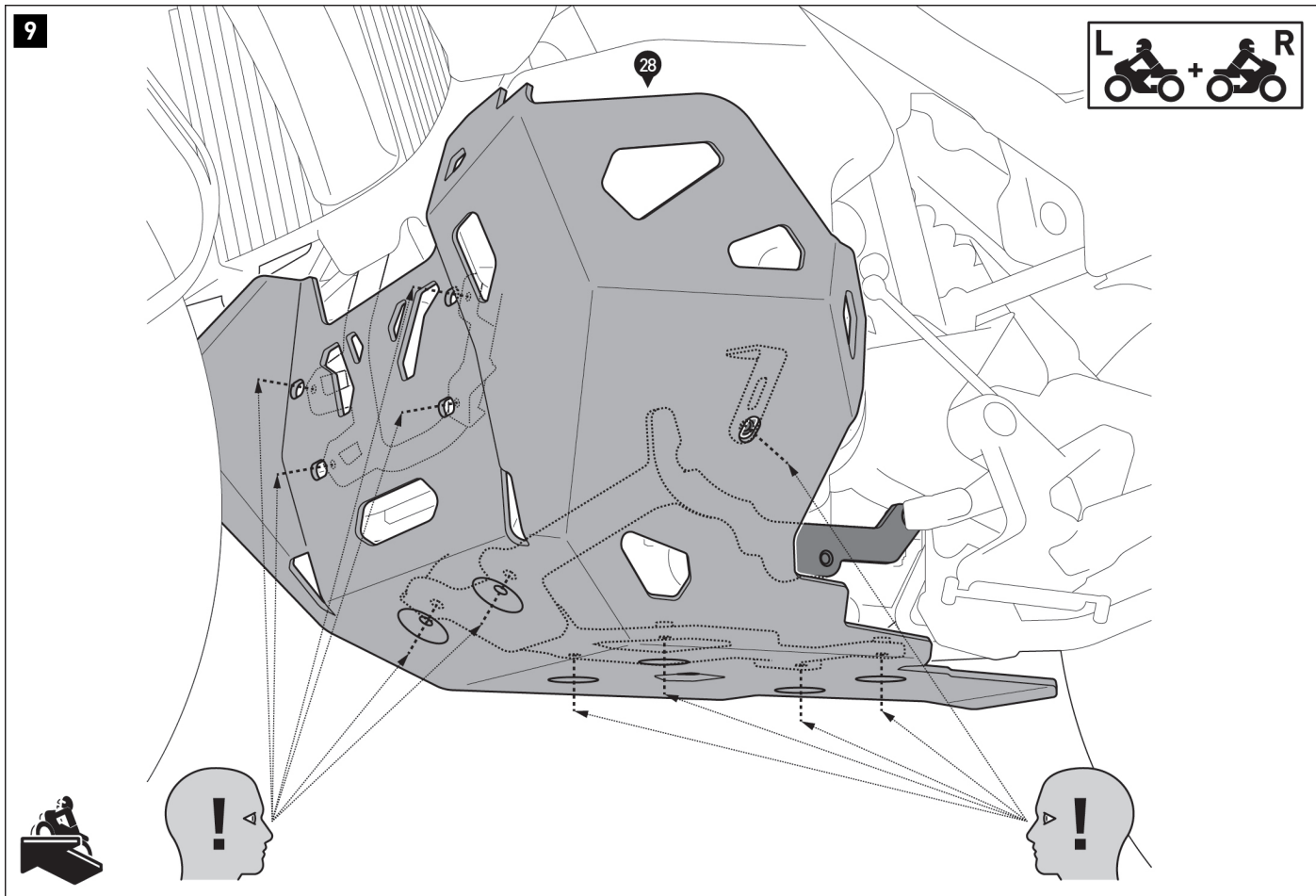

Con l'aiuto di una seconda persona, spingere la protezione del motore [28] contro tutte le staffe angolari, le staffe di montaggio e i punti di fissaggio anteriori originali precedentemente montati.

Assicurarsi che i fori delle viti della protezione del motore [28] coincidano con i punti di fissaggio delle staffe angolari, delle staffe di montaggio e dei punti di montaggio anteriori.  
Se necessario, regolare nuovamente i singoli componenti.

Rimuovere la protezione motore.



10

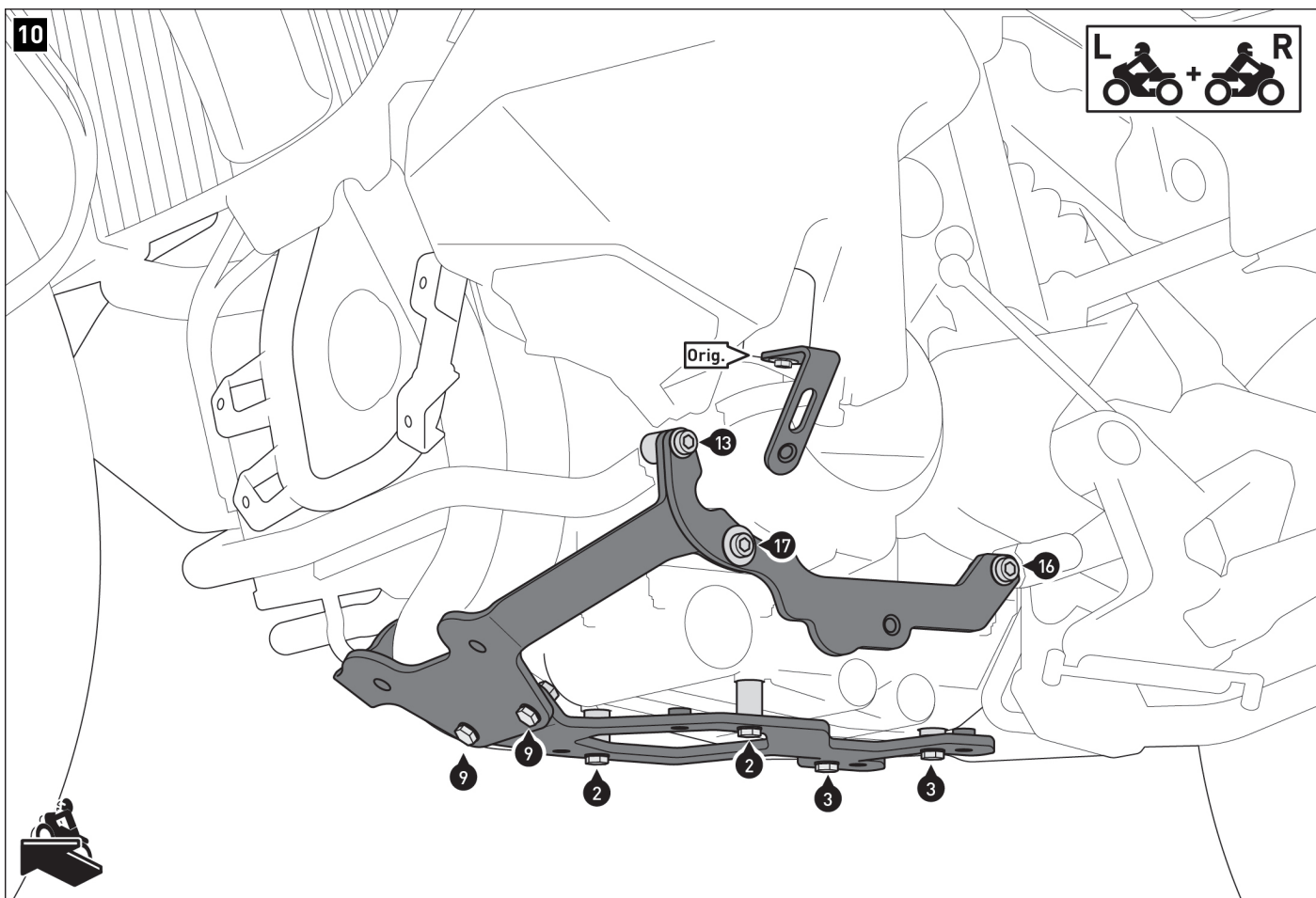

Serrare le viti nel seguente ordine: [13], [16], [20], [23], [2], [3], [17], [25], [9], [Orig.].

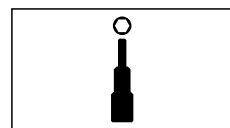
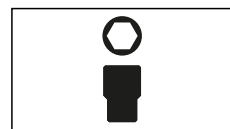
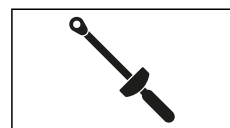

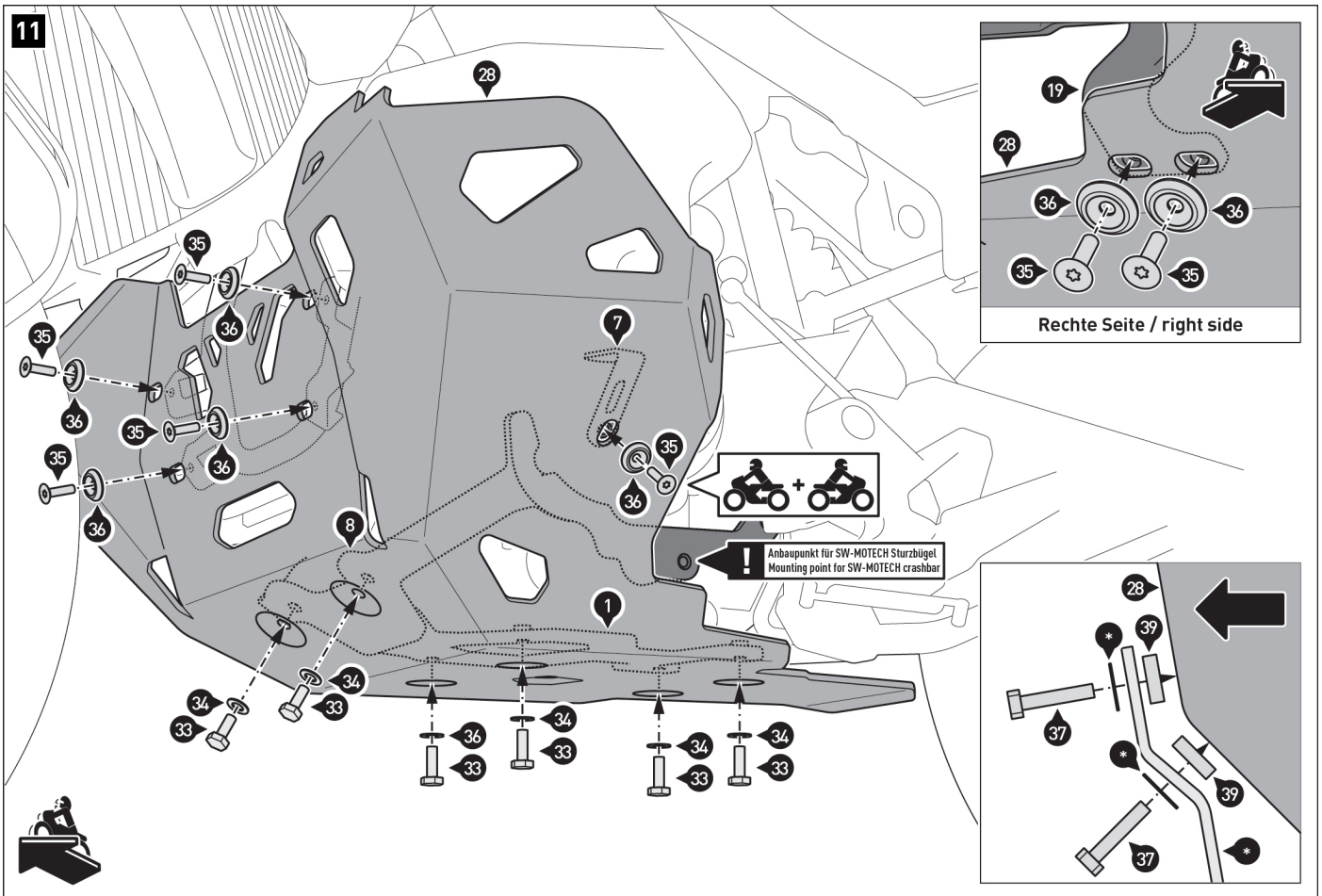

Avvitare la protezione motore [28] alle staffe angolari, alle staffe di montaggio e ai punti di montaggio anteriori.

**⚠ AVVERTENZA: Usare un frenafilietti liquido!**

Quando tutti i componenti sono posizionati senza tensione, serrare tutte le viti come specificato nelle istruzioni di installazione.

**⚠ AVVISO:** se la protezione motore è installata con la barra di protezione SW-MOTECH, le posizioni (35) e (36) non saranno più necessarie. Montare la protezione motore e la barra di protezione come mostrato in dettaglio nell'illustrazione sottostante (prima la protezione motore, poi la barra di protezione). Le parti contrassegnate (\*) sono incluse con la barra di protezione.

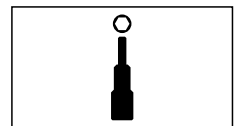
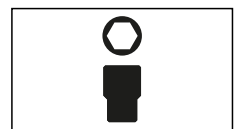
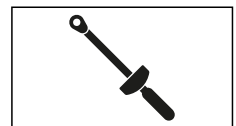
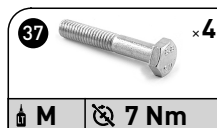
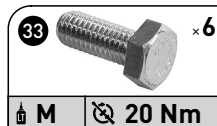

**AVVERTENZE SPECIFICHE DEL PRODOTTO**

**▲ AVVERTENZA:** l'altezza da terra potrebbe essere limitata da questo prodotto! Particolare cautela è richiesta in curva con angoli di inclinazione estremi e/o guida su terreni sconnessi (ad es. su cordoli e dossi)!

**▲ AVVERTENZA:** I tubi di scarico delle moto spesso presentano grandi tolleranze geometriche. Assicurarsi che vi sia una distanza sufficiente tra tutte i componenti nelle aree interessate!

**▲ AVVISO :**rispettare le normative nazionali specifiche per l'immatricolazione/l'uso del veicolo o le normative TÜV applicabili. Dopo il montaggio, far inserire le parti soggette a omologazione nei documenti del veicolo dal proprio centro di test.