

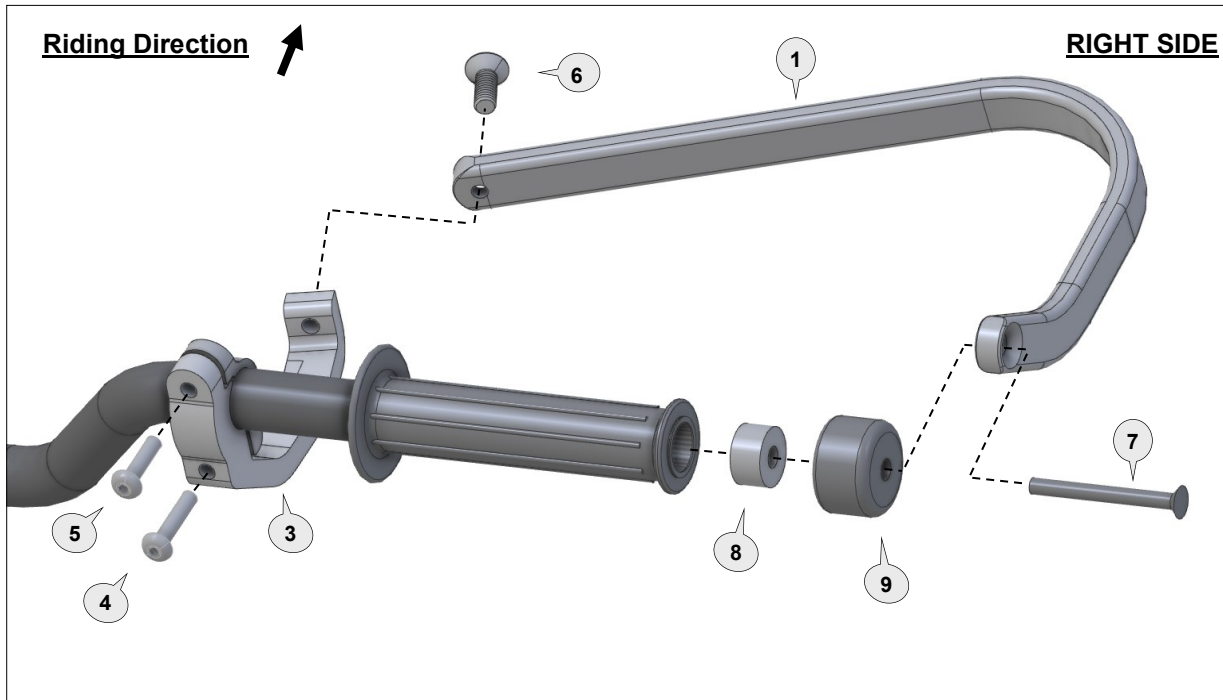

www.barkbusters.net

## FITTING INSTRUCTIONS for...

- Honda CL500 (2023-)



### Preparation

If OEM grips are installed, the end will need to be opened.

A video on how to do it can be found on Barkbusters.net or on the link below.

[Video - How to cut grips](#)

### Fitting Procedure shown for the RIGHT side

(repeat for Left side with applicable parts. Use spacer (10) instead of (8))

1. Loosely assemble clamp (3) to handlebar as per diagram.
2. Pre-assemble parts (7), (1), (9) and (8) and then present the assembly to the end of the handlebar, making sure the clamp (3) aligns with the end of the backbone (1).
3. Loosely tight screw (7) and (6). While making sure the assembly is in the right position,

**Note:** The preferred backbone position is horizontal when viewed from the side.

Tighten all bolts in the following order (7), (6), then (4 and 5).  
Use recommended torque specifications over page.

#### Bar Side View

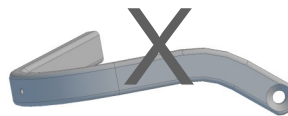
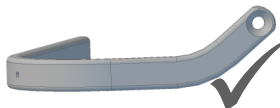

#### Personalise Your Protection

Guard options sold separately

<b>JET</b>	JET-003
<b>VPS</b>	VPS-003
<b>Storm</b>	STM-003
<b>CARBON</b>	BCF-003



INS-BHG-110-00-NP



Email: [info@barkbusters.net](mailto:info@barkbusters.net)  
[@BARKBUSTERSHANDGUARDS](#)

**1** Aluminium Bar



PN: BAR-BV-036  
Pcs. 2 (L & R)

**2** Clamp Frame & Saddle (left)



PN: CFS-ADV-L  
Pcs. 1

**3** Clamp Frame & Saddle (right)



PN: CFS-ADV-R  
Pcs. 1

**4** Button Head Bolt 30mm



PN: M6x30BHCSZP  
Pcs. 2

**5** Button Head Bolt 20mm



PN: M6x20BHCSZP  
Pcs. 2

**6** Flat Head Bolt 20mm



PN: M8x20FHCSZP  
Pcs. 2

**7** Flat Head Screw 60mm



PN: M6X60FHCSZP  
Pcs. 2

**8** Spacer (17mm) **RIGHT**



PN: SP17-20-8  
Pcs. 1

**9** Bar End Weight



PN: BEW35  
Pcs. 2

**10** Spacer (12mm) **LEFT**



PN: S7-SP12  
Pcs. 1

Recommended Torque Settings	
M6	10 Nm (7.4 lbf ft)
M8	20 Nm (14.8 lbf ft)

**CAUTION:**

Installation of the handguard is safety-relevant work and can be complicated. We recommend the installation be performed by a motorcycle service technician. Rideworx accepts no liability for damages caused by improper mounting. All screws, bolts and nuts, including all replacement hardware provided by Rideworx, should be tightened to the torque specified in the table. After the first 50km of riding check all screws, bolts and nuts are tightened to the correct torque. We recommend a medium strength liquid thread lock product on all fasteners.

**WARNING:**

Check operation of all handlebar controls, specifically the throttle, front brake, kill switch and clutch to ensure they are operating correctly and are in accordance with the OEM specifications. Do not ride the motorcycle if any controls are not operating correctly or if rear view mirror vision is obscured. Check periodically that all bolts are tight.



Phone: +61 (0)2 4271 8244  
Email: [info@barkbusters.net](mailto:info@barkbusters.net)  
Web: [www.barkbusters.net](http://www.barkbusters.net)



**Disclaimer:**

A failure to follow these fitting instructions could cause serious injury, death or property damage. These handguards are intended solely for use with motorcycles/ATV/snowmobiles/scooters that have not been modified. They are not designed to prevent injury or death while riding or in an accident or crash. The user must ensure that all controls are free of the handguards every time that they ride. By installing and/or using this product you acknowledge that you accept these terms and have followed the fitting instructions.

# Barkbusters

## FITTING INSTRUCTIONS for Carbon Fibre Handguard

Option for fitting with **Single Point Handlebar Mount** (sold separately)

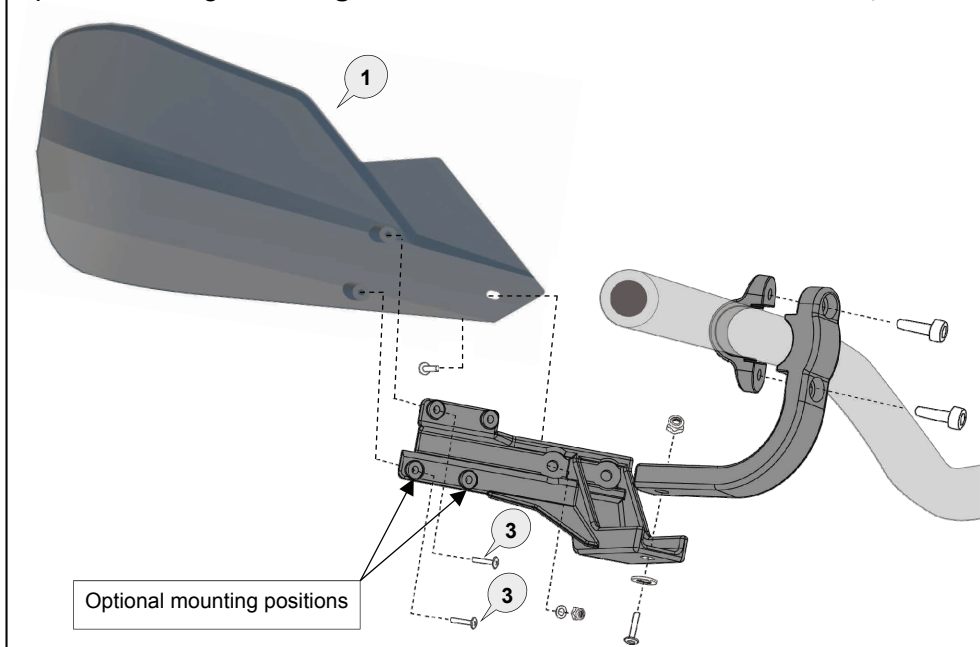

Option for fitting with Barkbusters **Aluminium Backbone** (sold separately)

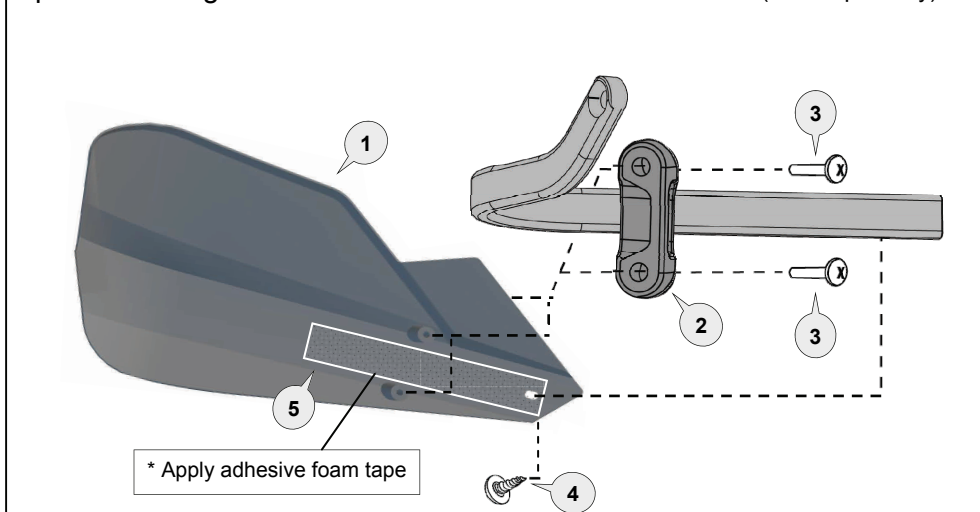

**1** Carbon Fibre Guard



PN: BCF

Pcs. 2 (L/R)

**2** Saddle



PN: Storm-Saddle

Pcs. 2

**3** Pan Head Screw



PN: M4x10PHZP

Pcs. 4

**4** Screw



PN: STSZ811MX11

Pcs. 2

**5** Foam Tape



PN: FT1

Pcs. 2

### CAUTION:

Installation of the handguard is safety-relevant work and can be complicated. We recommend the installation be performed by a motorcycle service technician. Rideworx accepts no liability for damages caused by improper mounting. All screws, bolts and nuts, including all replacement hardware provided by Rideworx, should be tightened to the torque specified in the below table. After the first 50km of riding check all screws, bolts and nuts are tight. We recommend a medium strength liquid thread lock product on screw (3).

### WARNING:

Check operation of all handlebar controls, specifically the throttle, front brake, kill switch and clutch to ensure they are operating correctly and are in accordance with the OEM specifications. Do not ride the motorcycle if any controls are not operating correctly. Check periodically that all bolts are tight.

### Disclaimer:

A failure to follow these fitting instructions could cause serious injury, death or property damage. These handguards are intended solely for use with motorcycles/ATV/snowmobiles/scooters that have not been modified. They are not designed to prevent injury or death while riding or in an accident or crash. The user must ensure that all controls are free of the handguards every time that they ride. By installing and/or using this product you acknowledge that you accept these terms and have followed the fitting instructions.



Phone: +61 (0)2 4271 8244  
Email: [info@barkbusters.net](mailto:info@barkbusters.net)  
Web: [www.barkbusters.net](http://www.barkbusters.net)